

การจัดการระบบการทำงานของเครื่องทดสอบฮาร์ดดิสก์อัตโนมัติ ให้มีประสิทธิภาพสูงสุด

สุวรรณชัย ตะกี้¹ และ วรพจน์ อังกลสิทธิ์²

มหาวิทยาลัยเทคโนโลยีพระจอมเกล้าธนบุรี แขวงบางมด เขตทุ่งครุ กรุงเทพฯ 10140

บทคัดย่อ

การทดสอบฮาร์ดดิสก์ในเครื่องทดสอบฮาร์ดดิสก์อัตโนมัติมีความสำคัญอย่างยิ่งต่อการผลิตฮาร์ดดิสก์เป็นส่วนสำคัญสำหรับผู้วางแผนการผลิตเพื่อให้ได้ผลผลิตตามเป้าหมาย การจัดการที่สำคัญได้แก่การจัดการเวลาในการนำฮาร์ดดิสก์เข้าเครื่องทดสอบ การจัดการลำดับของการนำฮาร์ดดิสก์เข้าเครื่องทดสอบ รวมถึงการจัดการขั้นตอนในการทดสอบฮาร์ดดิสก์ให้เหมาะสมกับช่องทดสอบของเครื่องทดสอบฮาร์ดดิสก์อัตโนมัติ กับรุ่นของฮาร์ดดิสก์ และรวมถึงช่วงเวลาของการทดสอบฮาร์ดดิสก์แต่ละรุ่น โดยมีวัตถุประสงค์ของการศึกษาเพื่อจัดการการทำงานในเครื่องทดสอบฮาร์ดดิสก์อัตโนมัติให้มีประสิทธิภาพสูงสุดโดยใช้หลักการของซิกซิกม่า (six sigma) รวมถึงหลักการของการจัดการลำดับ (Querying) การจัดการเวลา (Timing) และการจัดตาราง (Scheduling) เพื่อศึกษาพฤติกรรมการทำงานในการจัดการฮาร์ดดิสก์ของเครื่องทดสอบฮาร์ดดิสก์อัตโนมัติ จากการศึกษาพบว่าการจัดการระบบการทำงานของเครื่องทดสอบฮาร์ดดิสก์อัตโนมัติมีตัวแปรหลักอยู่ 10 ตัวแปรที่นำมาพิจารณา เพื่อศึกษาและใช้การวิเคราะห์ด้วยหลักการของซิกซิกม่า การจัดการลำดับ การจัดการเวลา และการจัดตาราง จากการวิเคราะห์พบว่ามีเพียง 10 ตัวแปรสำคัญที่มีอิทธิพลต่อการจัดการของเครื่องทดสอบฮาร์ดดิสก์อัตโนมัติ คือ ช่วงเวลาในการจัดลำดับของงาน กลุ่มงานที่ผิดแปลกจากกระบวนการของกลุ่มอื่น การจัดการช่วงเวลาการทำงานของงาน 2 ชนิดในเวลาเดียวกัน ช่วงเวลาที่คาบเกี่ยวกันระหว่างขั้นตอนที่กระทำเสร็จสิ้นแล้ว ช่วงเวลาความสัมพันธ์ของงาน ช่วงเวลาขั้นตอนการทำงานแบบคู่ขนาน การจัดกลุ่มของงานแต่ละกลุ่ม การทดแทนกระบวนการทำงานของงานแต่ละงาน การจัดตารางงานการหาจุดสมดุลและการจัดการแต่ละกลุ่มภายใต้ข้อกำหนดหรือข้อแม้ที่ได้จัดวางไว้ และได้มีการนำไปทดลองในการทดสอบ ส่งผลให้ทราบว่ามีเพียง 7 ตัวแปรเท่านั้น จาก 10 ตัวแปรหลัก ที่มีอิทธิพลต่อผลผลิตของการผลิต ซึ่งได้แก่ ช่วงเวลาการจัดลำดับของงาน การจัดการช่วงเวลาการทำงานของงาน 2 ชนิดในเวลาเดียวกัน ช่วงเวลาความสัมพันธ์ของงาน ช่วงเวลาขั้นตอนการทำงานแบบคู่ขนาน การจัดกลุ่มของงานแต่ละกลุ่ม การจัดตารางงาน การหาจุดสมดุลและการจัดการแต่ละกลุ่มภายใต้ข้อกำหนดหรือข้อแม้ที่ได้จัดวางไว้

คำสำคัญ : เครื่องทดสอบฮาร์ดดิสก์อัตโนมัติ / ระบบการจัดการเวลา / ระบบการจัดการลำดับการทำงานและกำหนดการ / ฮาร์ดดิสก์ / ระบบควบคุมการวางแผน

¹ นักศึกษาปริญญาโท, หลักสูตรการพัฒนาศามารถทางการแข่งขันเชิงอุตสาหกรรม สถาบันวิทยากรหุ่นยนต์ภาคสนาม

² อาจารย์, หลักสูตรการพัฒนาศามารถทางการแข่งขันเชิงอุตสาหกรรม สถาบันวิทยากรหุ่นยนต์ภาคสนาม

Maximized HDD Automatic Tester Utilization Management

Suwanchai Takee¹ and Vorapoch Angkasith²

King Mongkut's University of Technology Thonburi, Bang Mod, Thung Khru, Bangkok 10140

Abstract

The utilization and efficiency management for Hard Disk Drive (HDD) automatic tester is very important in HDD manufacturing. Planner needs to ensure that scheduled loading plans are not interrupted and met a master production scheduling (MPS) target. In order to maximize HDD automatic tester utilization rate, the queuing and scheduling management is critical. Therefore, the study is to develop an optimized approach that deploying Six Sigma methodology, Queuing, Timing and Scheduling theory. The study comprises a total of 10 factors used for evaluating and applying with Six Sigma methodology, queuing, timing and scheduling theory. The study identifies these 10 important factors which influence HDD automatic tester utilization. The 10 important factors are identified as follows: job sequence time optimization, job discontinues time, two job with completed processing time, continuous job constraints ready time, Inter-relationship among job release time, concentrated job parallel time, job concentrated belong customer or order, job denoted by its position, job completion a partial schedule and job established under condition define. Furthermore, a Design of Experiments (DOE) is conducted and reveals that only 7 factors from 10 factors are influence to utilization level. They are job sequence time optimize, two job with completed processing time, inter-relationship among job release time, concentrated job parallel time, job concentrated belong customer or order, job completion a partial schedule and job established under condition define to achieve the MPS loading plan.

Keywords : Automatic Tester Utilization / Time Management / Queuing Management and Scheduling Management / Hard Disk Drive (HDD) / Master Plan System (MPS) / Design of Experiments (DOE)

¹ Master Degree Student, Development of Industrial Competitiveness Program, Institute of Field Robotics.

² Lecturer, Development of Industrial Competitiveness Program, Institute of Field Robotics.

1. Introduction

Hard disk drive manufacturing industry involves high technology deployment. This industry is continually searching an improved new technology

and innovation ideas to stay competitive in this business. The basic of HDD manufacturing processes are shown in Fig.1

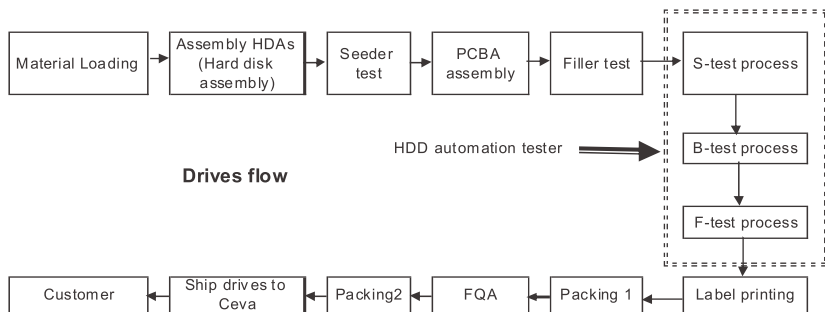

Fig. 1 HDD manufacturing process flow diagram.

HDD industry is continuously searching for advanced technology and testing equipment to support a high volume manufacturing to achieve an economy of scale. Presently, there are 2 types of testing equipment (HDD automatic tester and HDD manual tester) available to support HDD manufacturing testing and write format signal in order to their customer configuration. The HDD automatic tester is new technology equipment for supporting HDD testing that demonstrates better utilization and quality than HDD manual tester. However, a set of HDD automatic test process still follow HDD manual tester process. The creation of HDD automatic tester is to increase quality, efficiency of test and write signal format per customer requirement. Therefore, this research is oriented towards improving quality, maximizing utilization and increasing productivity by deploying HDD automation tester infrastructure. This new testing paradigm is not only for efficiency enhancement but also for reducing product cost and satisfying customer requirements.

A HDD automatic tester has 2 cells used for testing hard disk drives as follow:

I-Cell is for testing hard disk drives under control temperature with an interface circuit card in order to communicate with information system when writing data signal into hard disk drives.

B-cell is for testing hard disk drives under control temperature without an interface circuit card when write data signal into hard disk drives. B-cell functionality is different from I-cell. B-cell has a mechanical check capability for hard disk drives and communicates with information system after testing completed.

2. HDD Automatic Testing Process

Each HDD automatic tester has many testing slots. Each slot has 2 cells both drive are tested at the same time. In automatic testing processes, the tester has 3 steps of testing. It starts from drives movement to a presenter of a tester, and then its robot move search of them from a presenter to a testing cell. The sequence of testing consists of 3 steps; firstly subjecting to 1st testing process (S), then 2nd testing process (B) and 3rd testing process (F). In case of a failure occur in any of the 3 steps

testing, a failed drive is removed after a drive complete its step A failed drives is removed from HDD automatic tester. Then, they are disposed to manual testing process called BE debugging

process for failure confirmation before disposing them to be torn down or retested in HDD automatic tester again. The testing processes are shown in Fig. 2.

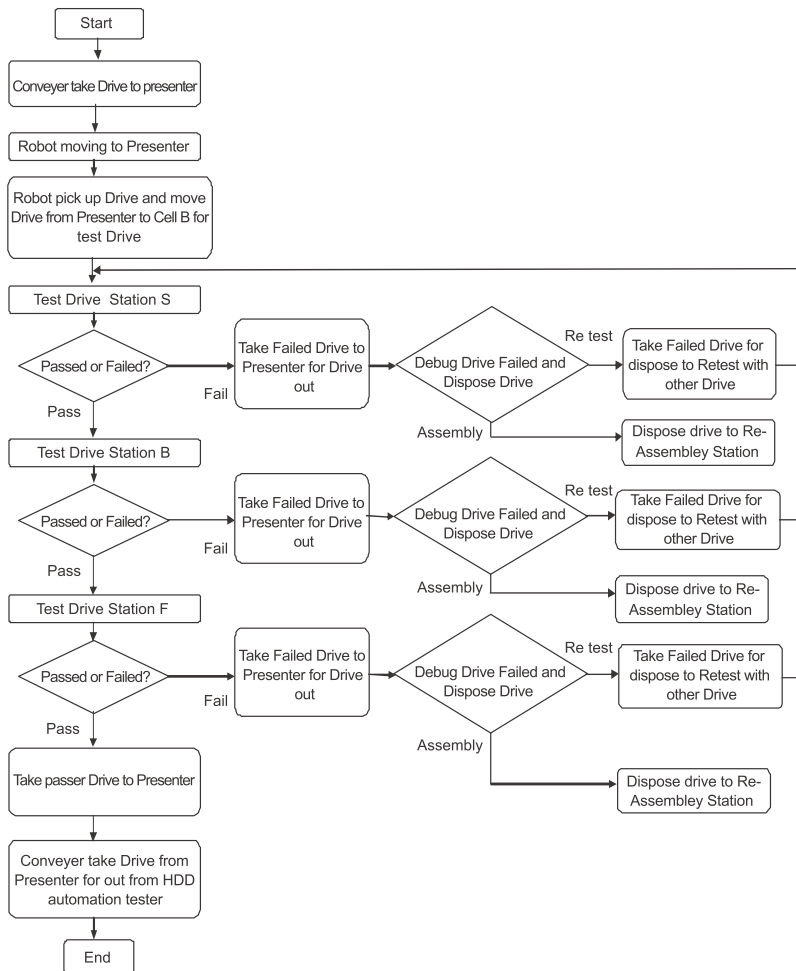

Fig. 2 HDD automatic testing process flow diagram.

The study of Six Sigma to improve a testing process is conducted as follows: Maintaining the integrity of the specifications. The main purpose of Six Sigma is to improve and reduce structural abnormalities during the testing process. The sequence of analysis processes of HDD automatic tester consists of Define, Measure, Analysis, Improve and Control (DMAIC).

Define: defines a problem and explains a problem to settle an objective to improve processes. This research defines to improve process by implement queuing theory for managing drive testing process for HDD automatic tester in each station. Also, a set of timing, scheduling and queuing theory method are introduced to improve processes. These include analysis input process, in process and output process

as hard disk drive's test process by applying timing management practice "FCFS" discipline (First come First served) [1].

Measure: measures current as a baseline and comparing its after improvement

Analysis: verify and find out the data relative including root cause that happens from abnormal process constant.

Improve: improve manufacturing testing process of hard disk drives as referring analysis result from design experiment.

Control: control the abnormal constants in processes of hard disk drive testing by simulating from original design before releasing them to use in testing process and continue monitor its processes.

3. Methodology

A. Root cause and effective map

Root cause and effective mapping is used for analysis of possible processing constants that may affect to change operation management of HDD automatic tester. To find out the root cause, problem sources are analyzed which they may happen from manpower, methods, processes and HDD automatic testing machines.

Thus, root cause and effective mapping analysis focus on minimizing input resource that obtain from relationship of resources between input and output as shown in Fig. 4.

Some of the process variables and material properties x_1, x_2, \dots, x_p are controllable, whereas other z_1, z_2, \dots, z_p are uncontrollable. The objectives of the experiment may include the following. [2]

1. Determining with variable are most influential on response Y
2. Determining where to set the influential X's so that Y is almost always near the desired nominal value

3. Determining where to set the influential X's so that variability in Y is small.
4. Determining where to set the influential X's so that the effect of the uncontrollable variable z_1, z_2, \dots, z_p are minimized.

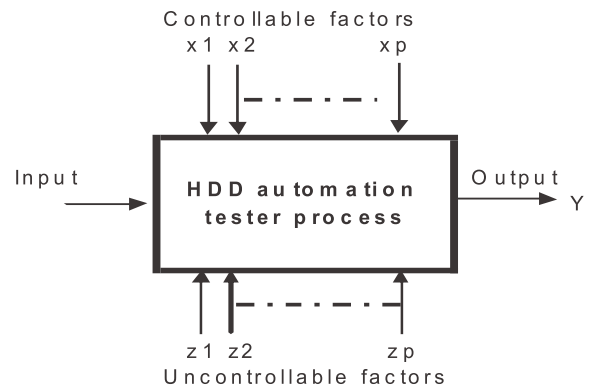

Fig. 3 Analysis of HDD automatic tester operation from efficiency theory.

Efficiency Analysis concept is intended to increase efficiency [3] as Efficiency = Output/Input

- Reduce input, maintain out put
- Maintain input, increase out put, need to focus.
- Increase/reduce input or output

B. Process mapping

Process mapping is used to analyze and made to clarify the main processes, input constants and output constants for consideration. The process mapping is used to identify the importance of input to output transformation.

C. Priority of analysis method

An analysis critical method with 10 important keys are job sequence time optimize [4], job discontinues time [5], two job with completed processing time [6], continuous job constraints ready time [7], inter-relationship among job release time [8], concentrated job parallel time [9], job

concentrated belong customer or order [10], let job denoted by its position [11], job completion a partial schedule [12] and job established under condition define [13]. Referring to the experiment analysis for managing priority of analysis method selection comprises 2 steps:

1. Select hard disk drives by each capacity or model including material for testing. The selected method is considered between input constant and output constant that is set for the entire constant to separate analysis between I-cell and B-cell for testing of each product and model as table below.

Product	Drives Capacity	Required Configuration	
		I	B
Product A	16X	0	/
Product A_PMR	16X	0	/
Product A_PMR_RE	16X	/	/
Product B	50X	0	/
Product C	32X	0	/
Product C_RE	32X	/	/

0= not use, / = use

Fig. 4 Separating I-cell and B- cell for testing of each product and model.

2. Scheduling management to manage all jobs under all conditions.

The process depends on cycle time of all 3 steps as shown in Fig. 6. The need to manage test cycle time depend on HDD model or capacity.

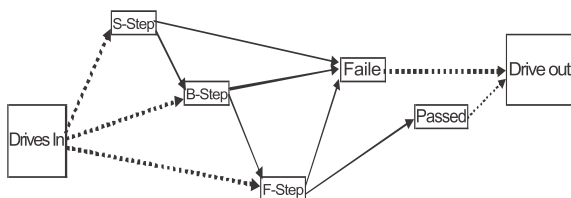

Fig. 5 Test cycle time process flow.

Test cycle time for a cell which comprises two jobs should be same. As shown in Fig. 6, it described the test process of 2 hard disk drives at the same time, which depends on process or sequence of hard disk drives status.

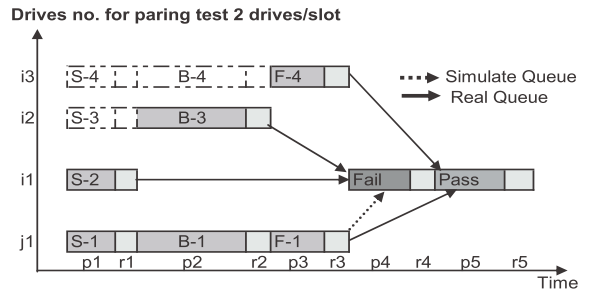

Fig. 6 Test process of 2 hard disk drives at the same time and same sequence.

The test timing is related to the time of loading hard disk drives in to HDD automatic tester. Considering concept of scheduling from sequencing (S) [14], the sequence of drives should be in the same station so the process is continued testing process. For this condition, disk j will follow up disk i, so $P_i < P_j$ and $r_i < r_j$

$$F = \max \{t, r_i\} + p_i + \max \{t, r_j\} + p_j - 1$$

where:

t: Timing process continue of 2 hard disk drives

F: All timing process of all hard disk testing

j: Hard disk drives no. j^n

i: Hard disk drives no. i^n

p: Processing time as each sequence

r: Timing Release of hard disk drives per each sequence

In case of interchange ($P_i < P_j$ and $r_i < r_j$) for new Process, S' are:

$$F' = \max \{t, r_i\} + p_i + \max \{r_j, \max \{t, r_i\} + p_i\} + p_j - 2$$

Then,

$$F - F' = (\max\{t, r_j\} - \max\{t, r_i\}) + (p_j + \max\{t, r_j\} - \max\{r_j, \max\{t, r_i\} + p_i\}) \text{ ---3}$$

Condition $p_i < p_j$ and $r_i < r_j$, then $\max\{t, r_j\} - \max\{t, r_i\} > 0$ and $p_j + \max\{t, r_j\} - \max\{r_j, \max\{t, r_i\} + p_i\} > 0$. From 3 : $F' - F < 0$. In case $P_i = P_j$ and $r_i = r_j$ then,

$$F = \max\{t, r_j\} + p_j + p_i \text{ ---4}$$

In case interchange ($P_i = P_j$ and $r_i = r_j$) for new Process, S'

$$F' = \max\{r_j, \max\{t, r_i\} + p_i\} + p_j \text{ ---5}$$

In case of 2 hard disk drives operating in parallel will get F as follow

$$F = \max\{r_i, r_j\} + \max\{p_j, p_i\} \text{ ---6}$$

measured from loading hard disk drives for testing (input) and removing hard disk drives out from HDD automatic tester. The efficiency measuring for HDD automatic tester has 2 measurement stages (i.e. measure hard disk drive load in and out from machine). The HDD automatic tester utilization definition includes inline debug disposition as failed in process. Also if a failed drive is not a real failure as it may be a result from testing process error then this hard disk drive need to retest at the same station that previously failed. The retest process is considered similar to a new loading of hard disk drives and should be considered for utilization calculation.

D. Measurement analysis

Measurement analysis is experimented for consider an abnormal of a measurement process that impact all process. This research is referred to operating time management, working loop, scheduling and sequencing operation. They can be

E. Ability of test process

Test process ability is a measurement process that concerning with test cycle time for each model. Refer CPK data that monitor 82 machines utilization (period about one week) before improvement as shown in Fig.7 and Fig. 8.

Parameter/ Drives capacity	16X	25X	32X	50X	75X	Over all
Upper specification loading limit / machine per day	2011	1823	1678	1453	1371	1667.2
Average per machine per 6 days	1673	1290	1207	1016	937	1216
Stdev per machine per 6 days	420.27	226.6	254.51	259.91	173.96	368.87
Cpk per machine per 6 days	0.26808	0.78405	0.61687	0.56045	0.83161	0.40773
Count days	6	6	6	6	6	6
Count HDD automation tester	14	23	8	29	8	82
Utilization	69.57%	71.24%	82.98%	77.39%	66.69%	73.57%

Fig. 7 CPK data that monitoring 82 machines before improvement.

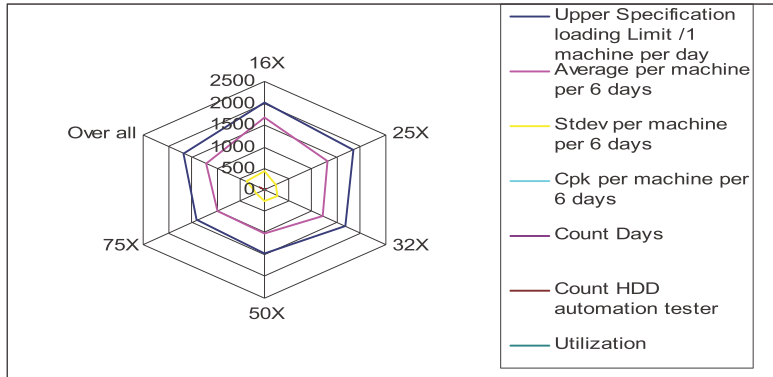

Fig. 8 Chart of monitoring 82 machines before improvement.

4. Design of Experiment

Design of experiment is develop to determine the relation between input process constant (P_j) and in process constant (r_i) that effect with all result constant (F). The result of experiment is analyzed to study the influence of each input process constant. Thus, plan to experiment design 3 steps as follows [15]:

1. Fraction factorial design is used for selecting the input process constants
2. Full fractional design is used to understand the process, relative between input processes constant and respond result constant.
3. Central composite design is used to adjust the process comfortable.

After the experiment, the result shows that only 7 important keys of input process constant are influence to the utilization. They are job sequence time optimize, two job with completed processing time, inter-relationship among job release time, concentrated job parallel time, job concentrated belong customer or order, job completion a partial schedule and job established under condition define. They are selected from process measurement and analysis. The design process management can be applied for design experiment inline debug system

inside HDD automatic tester as shown in Fig. 9. It results on the reduction of handling time for loading and taking out hard disk drives from HDD automatic tester. Also, inline debug system increases utilization and operation efficiency of HDD automatic tester.

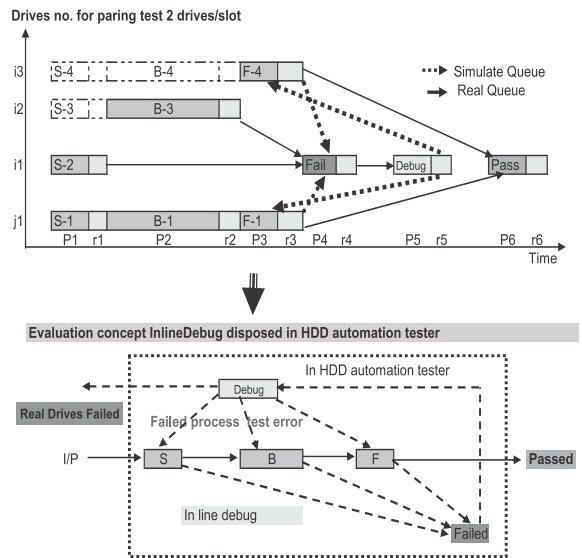

Fig. 9 Diagram for experiment inline debug in HDD automatic tester.

Fraction Factorial Design, Full Fractional Design and Central Composite Design for design and experiment inline debug details as follow:

Fraction Factorial design is selected and considered for the important of input process constant. A process measurement analysis is to consider two jobs with completed processing time, cycle time of job no. 1, cycle time of job no. 2. The design includes processing cycle time, cycle time between complete of each processing, total cycle time of processing and interchange or intercept new processes.

Full Fractional Design considers relation of input process constants that respond to themselves. The concept is to consider constants that refer to capacity of hard disk drives, cycle test time of hard disk drives, test sequence of hard disk drives, cycle test time of debug dispose, and cell availability in HDD automatic tester. This analysis is shown in Fig. 10.

Capacity of Hard disk drives	Test time of S-step (Hrs)	Test time of B-step (Hrs)	Test time of F-step (Hrs)	Debug disposition test time (Min)	Cell HDD automation tester
16X	5.00	10.97	6.22	14.00	B
25X	7.41	18.31	7.91	14.30	B
32X	7.50	20.79	8.57	14.50	B
50X	9.72	33.26	8.70	15.40	B
75X	10.46	36.18	10.50	16.00	B

Fig. 10 The analysis of Full Fractional Design process for design constant to experiment inline debugs.

Central Composite Design considers adjusting the process to comfort level. The process for this research is to be adjusted for test sequence including loading and movement process from current to be better one. Inline debug is design to improve this process for increase utilization of HDD automatic tester.

5. Evaluation

Regarding evaluation of inline debug process in HDD automatic tester and the change of test process from 3 steps to 1 step that gain 20% of utilization improvement for HDD automatic tester as comparing data before and after implementation as shown in Fig. 11.

Capacity/Date	1st	2nd	3rd	4th	5th	6th	7th
16X	94.79%	94.29%	93.86%	93.43%	93.52%	93.71%	91.81%
25X	91.96%	96.12%	95.94%	96.87%	93.78%	82.81%	87.68%
32X	95.55%	94.69%	94.65%	96.04%	95.98%	95.15%	95.29%
50X	91.72%	93.54%	94.15%	95.21%	95.81%	95.44%	95.81%
75X	96.97%	95.13%	96.13%	95.88%	95.42%	95.20%	95.94%
day overall Utilization %	94.20%	94.75%	94.95%	95.49%	94.90%	92.46%	93.31%

Fig. 11 The utilization after implementing inline debug system in HDD automatic tester.

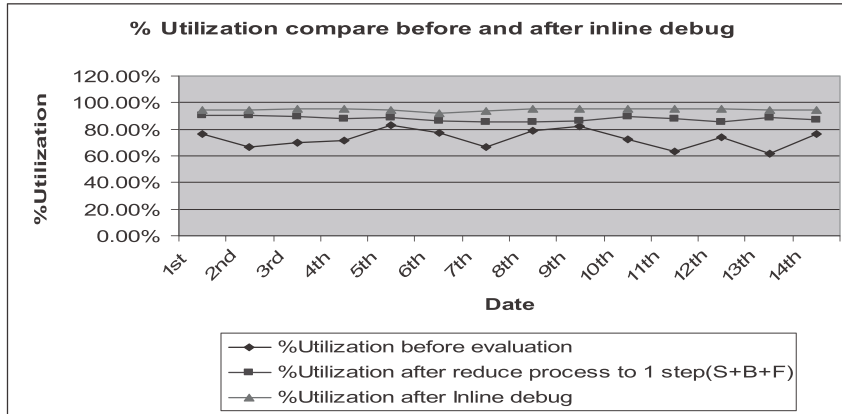

Fig 12. The utilization before and after implementing inline debug system.

6. Summary and Conclusion

The study of inline debug experiment is based on 7 important keys for input processing constant. They are job sequence time optimize, two job with completed processing time, inter-relationship among job release time, concentrated job parallel time, job concentrated belong customer or order, job completion a partial schedule and job established under condition define. They are selected from process measurement and analysis by six sigma method, fraction factorial design, full fractional design and central composite design. This design of experiment was set up to improve hard disk drive testing and inspection. It is also used to manage hard disk drives utilization HDD automatic tester. This research provides a methodology to optimize HDD automatic tester utilization called "Inline Debug System". The conclusion of this study show that the inline debug system significantly improve hard disk drive testing ability on capacity, test time analysis, test queue, priority of test processing, debug disposition period, quantity of cell loading and cell loading types. The study shows a gain of 20% of utilization improvement for HDD automatic tester.

7. Acknowledgement

This study was funded by Industry/University Cooperative Research Center in HDD Advanced Manufacturing and National Electronics and Computer Technology Center, National Science and Technology Development Agency. The opinions and results in this study may or may not be agreeable by the agencies mentioned above.

8. References

- Wayne L. Winston, 4th Edition, *Operation Research Application and Algorithms*, Brooks/Cole-Thomson Learning 10 Davis Drive Belmont, CA 94002.
- Ronald G. Askin, Charles R. Standridge, *Modeling and Analysis of Manufacturing System*, John Wiley & Sons Inc, United State of America.
- Chu, C., 1992, "Efficient Heuristics to Minimize Total Flow Time with Release Dates", *Operations Research Letters*, Vol. 12, pp. 321-330.
- Graham RL, Lawler EL, Lenstra JK, Rinnooy Kan AHG., 1979, "Optimization and Approximation in Deterministic Machine Scheduling: a Survey", *Annals of Discrete Mathematics*, Vol. 5, pp. 287-326.

5. Dessouky MI, Deogun JS., 1981, "Sequencing Jobs with Unequal Ready Times to Minimize Mean Flow Time", *SIAM Journal on Computing*, Vol. 10, pp. 192-202.
6. Belouadah H, Posner ME, Potts CN., 1992, "Scheduling with Release Dates on a Single Machine to Minimize Total Weighted Completion Time", *Discrete Applied Mathematics*, Vol. 36, pp. 213-231.
7. Dessouky MI, Deogun JS., 1981, "Sequencing Jobs with Unequal Ready Times to Minimize Mean Flow Time", *SIAM Journal on Computing*, Vol. 10, pp. 192-202.
8. Lenstra JK, Rinnooy Kan AHG, Brucker P., 1977, "Complexity of Machine Scheduling Problems", *Annals of Discrete Mathematics*, Vol. 1, pp. 343-362.
9. Baker KR., 1974, *Introduction to Sequencing and Scheduling*. New York:Wiley.
10. Hall NG, Potts CN., 2003, "Supply Chain Scheduling: Batching and Delivery", *Operations Research*, Vol. 51, pp. 566-584.
11. Cheng TCE, Gordon VS, Kovalyov MY., 1996, "Single Machine Scheduling with Batch Deliveries", *European Journal of Operational Research*, Vol. 115, pp. 227-283.
12. Smith WE., 1956, "Various Optimizers for Single Stage Production", *Naval Research Logistic Quarterly*, Vol. 3, pp. 59-66.
13. Bianco L, Ricciardelli S., 1982, "Scheduling of a Single Machine to Minimize Total Weighted Completion Time Subject to Release Dates", *Naval Research Logistics Quarterly*, Vol. 29, pp. 151-167.
14. Mahdavi Mazdeh M., 2005, *Minimizing the Sum of Flow Times with Batching and Delivery in a Supply Chain*, PhD Thesis, Brunel University, England.
15. Douglas C. Montgomery, *Design and Analysis of Experiment*, ISBN 0-471-48735-X, WIE ISBN 0-471-66159-7.

